



DEVETECH ELECTRONICS CO. LTD

BUZZER
CUSTOMER: DACHS ELECTRONICA
P/N: DVZ-1707T2P40B

DESIGNED BY	
CHECKED BY	
APPROVED BY	

Address: 11/F.,F.Block, Hang Lok Building, 130Wing Lok St., Hong Kong.
Address: A3L1, Youpinyishu, Huanmei Rd., Dameisha, Yantian district, Shenzhen, China
Tel: (86) 13632770721 Email: sales@devetechelectronics.com Website: www.devetechelectronics.com



CONTENTS		
N°	Contents	Page
-	Cover	1
-	Contents	2
-	Document Revision History	3
1	Scope	4
2	Specification	4
3	Soldering conditions	4
4	Appearance drawing	5
5	Frequency characteristics	5
6	Electrical and acoustic measuring conditions	6
7	Reliability	7



Document revision history				
Change N°	Date	Subject and reason	Version N°	Responser
	2017-02-23			



1. Scope

This specification applies magnetic buzzer, DVZ-1707T2P40B

2. Specification

No.	Item	Unit	Specification	Condition
1	Operating voltage range	Vp-p	3.0~30.0	
2	Rated voltage*	Vp-p	12.0	
3	Rated current (mA)	mA	5	
4	Fundamental frequency*	Hz	4000	
5	Min. sound pressure level*	dB	85Min	At 12Vp-p/10cm
6	Operating temperature	°C	-20°C~+60	
7	Storage temperature	°C	-30°C~+70	
8	Dimension	mm	Φ17*H6.8	See appearance drawing
9	Outer covering material		PBT	
10	Environmental protection regulation		RoHS	

3. Soldering conditions

Buzzer soldering process	Soldering Parameter	
	Temperature (°C)	Time (Sec.)
Reflow soldering	255±5	220~255°C 40s
Wave soldering	255±5	3~4s
Manual soldering	320~350	2~3s

Remark: Instance Soldering Process

4. Appearance drawing

TOL: ± 0.5 Unit: mm

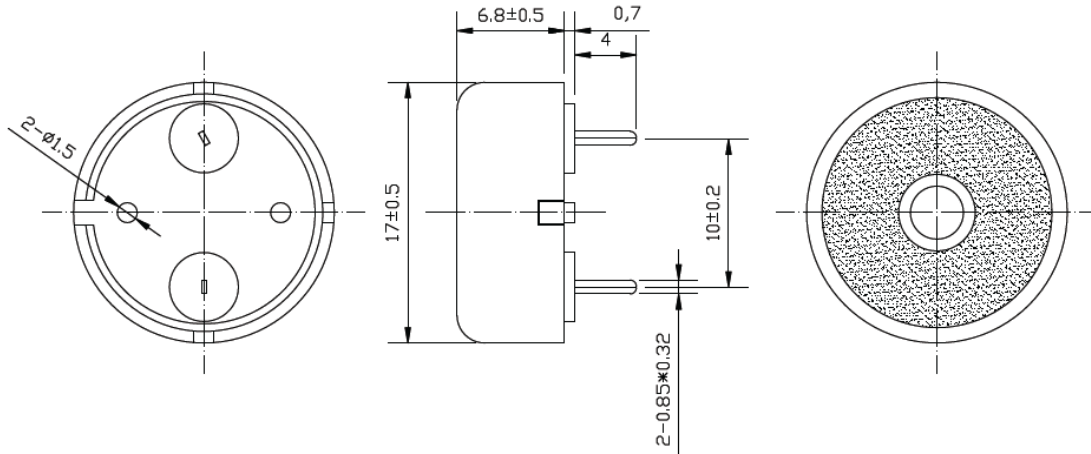

5. Frequency characteristics

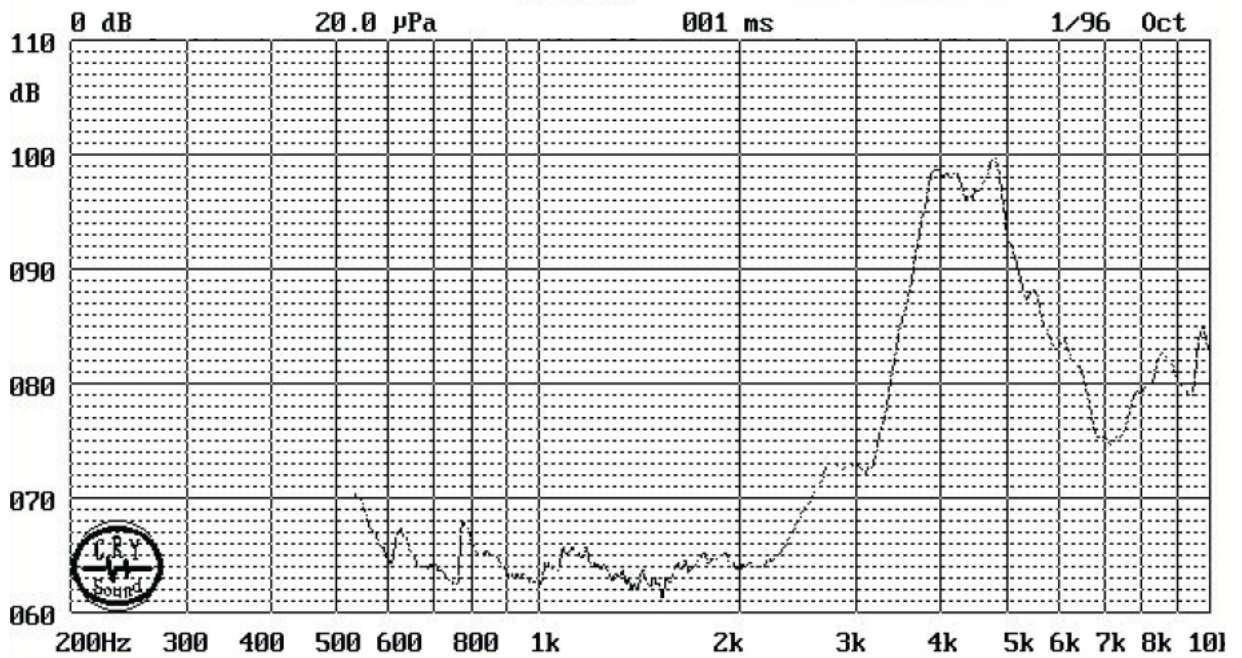

6. Electrical and acoustic measuring condition

Recommended setting

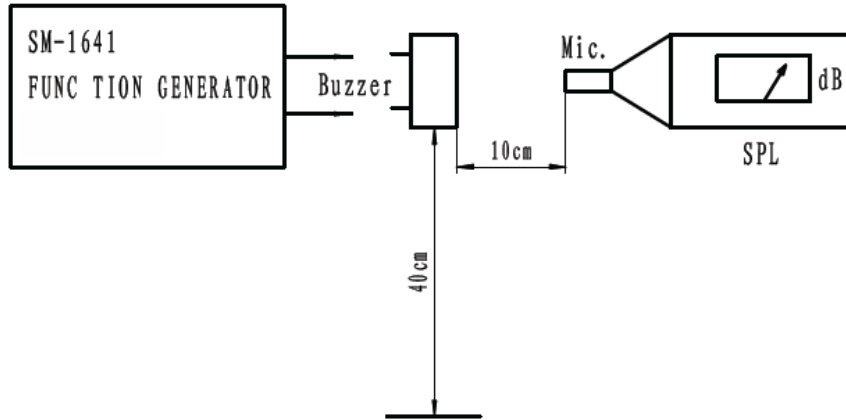

Acoustic characteristics

The oscillation frequency, current consumption and sound pressure are measured by the measuring instruments shown below:

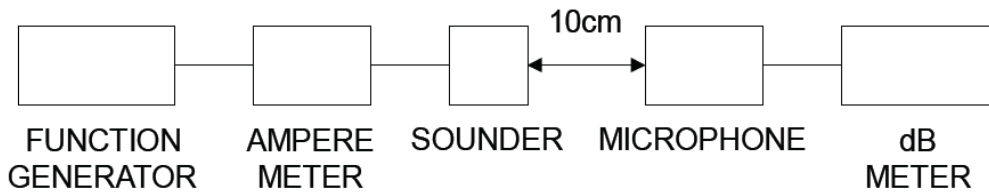

In the measuring test, buzzers are placed as follows:

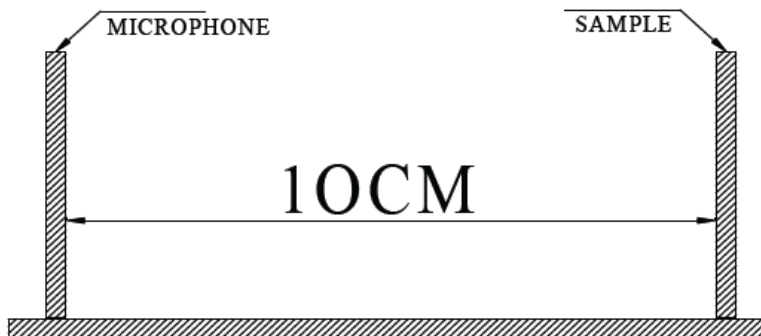

7. Reliability

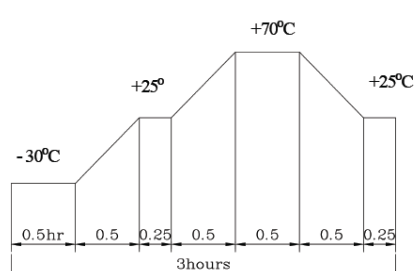
No	Item	Test condition and requirement
1	High temperature test	After being placed in a chamber with $70\pm 2^{\circ}\text{C}$ for 48 hours and then being placed in normal condition for 2 hours. Allowable variation of SPL after test $\pm 10\text{dB}$. Other performance must be within 10%
2	Low temperature test	After being placed in a chamber with $-30\pm 2^{\circ}\text{C}$ for 48 hours and then being placed in normal condition for 2 hours. Allowable variation of SPL after test $\pm 10\text{dB}$. Other performance must be within 10%
3	Humidity test	After being placed in a chamber with 80-85% RH at $40\pm 2^{\circ}\text{C}$ for 48 hours and then being placed in normal condition for 2 hours. Allowable variation of SPL after test $\pm 10\text{dB}$. Other performance must be within 10%
4	Temperature cycle test	<p>The part shall be subjected to 5 cycles. One cycle shall be consist of:</p>  <p>And then being placed in a normal condition for 2 hours. Allowable variation of SPL after test $\pm 10\text{dB}$. Other performance must be within 10%</p>
5	Solderability	Lead terminals are immersed in rosin for 3 seconds and then immersed in solder bath of $+330\pm 5^{\circ}\text{C}$ for 3 seconds. 90% min. lead terminals shall be wet with solder (except the edge of terminals)
6	Operating life test	48 hours continuous operation at $+60^{\circ}\text{C}$ with rated voltage applied and then being placed in normal condition for 2 hours. Allowable variation of SPL after test: $\pm 10\text{dB}$. Other performance must be within 10%
7	Drop test	Monomer from 75 cm high, X, Y, Z, three directions, the 3 times, naturally fall on the ground. Allowable variation of SPL after test: $\pm 10\text{dB}$. Other performance must be within 10%

Test condition

Standard test condition:

a) Temperature: $+5\sim +35^{\circ}\text{C}$ b) Humidity: 45-85% c) Pressure: 860-1060mbar

Judgment test condition:

a) Temperature: $+25\pm 2^{\circ}\text{C}$ b) Humidity: 60-70% c) Pressure: 860-1060mbar

