



DEVETECH ELECTRONICS CO. LTD

DVZ-ACQ3023220
CUSTOMER: DACHS ELECTRONICA

DESIGNED BY	
CHECKED BY	
APPROVED BY	

Address: 11/F.,F.Block, Hang Lok Building, 130Wing Lok St., Hong Kong.
Address: A3L1, Youpinyishu, Huanmei Rd., Dameisha, Yantian district, Shenzhen, China
Tel: (86) 13632770721 Email: sales@devetechelectronics.com Website: www.devetechelectronics.com

DVZ-ACQ3023220 Series



Dimensions

Unit: mm Tolerance: ± 0.5

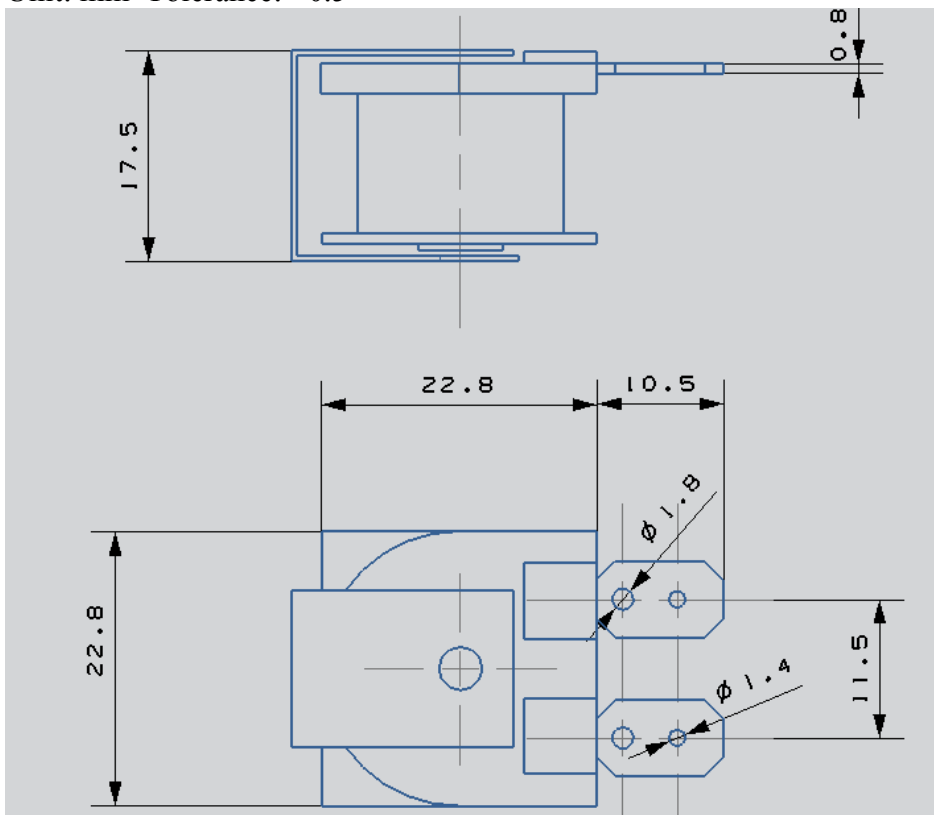

Specifications

Model N°	DVZ-ACQ3023220
Rated Voltage	220VAC
Operating Voltage	60 250VDC
Max. Rated Current	250mA at 12VDC
Min. Sound Pressure Level	85dB
Operating Temperature	-20°C~+125°C
Weight	18g



DEVETECH ELECTRONICS CO. LTD

NOTES
