



# Light Emitting Diode Lamp



## Specification For Approval

Customer :

Description : LED Lamp

Part Number : B3b-142-TR

Date : 2007.12. 11

**Approved By:**

--

**Prepared By:**

Checked	QC	Designed	Sales

Date: 2007/12/11

### ★ Package Dimensions

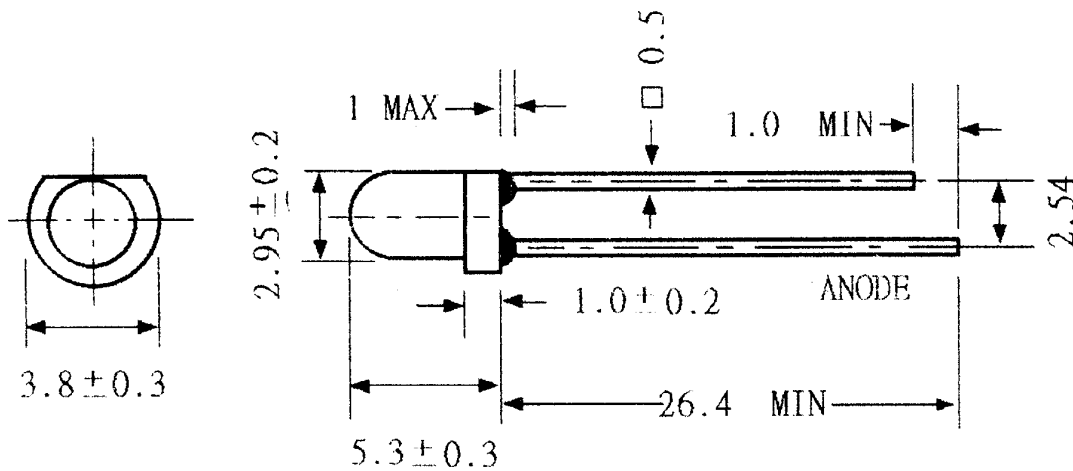

#### NOTE:

1. All dimensions are in millimeter.
2. Lead spacing is measured where the lead emerge from the package.

### ★ Selection Guide

Part NO.	Chip		Lens Color	Viewing Angle $2\theta$ 1/2(deg)
	Material	Emitted Color		
B3b-142-TR	GaP	Hi- Red	Red diffused	40

### Part No:B3b-142-TR

#### ★Absolute Maximum Ratings (Ta=25°C)

Parameter	Symbol	MAX. Rating	Unit
Power Dissipation	Pd	80	mW
Continuous Forward Current	IF	30	mA
Pak forward current (10 μs Pulse)	IFM	100	mA
Reverse Voltage	VR	5.0	V
Operating Temperature	Topr	-40~+85	°C
Storage Temperature	Tstg	-40~+85	°C
Lead Soldering Temperature (1.6mm From Case Bottom 260°C For 5 SEC)			

#### ★Electric-Optical Characteristics

Parameter	Symbol	Test Condition	MIN	TYP	MAX	Unit
Forward Voltage	VF	IF=20mA		2.0	2.6	V
Reverse Voltage	VR	IR=10uA	5			V
Luminous Intensity	IV	IF=20mA	2	5		mcd
Peak Emission Wavelength	λ P	IF=20mA		700		nm
Spectrum Width Of Half Value	Δ λ	IF=20mA		100		nm

#### ★Characteritics Diagrams

##### Hi-Red (GaP)

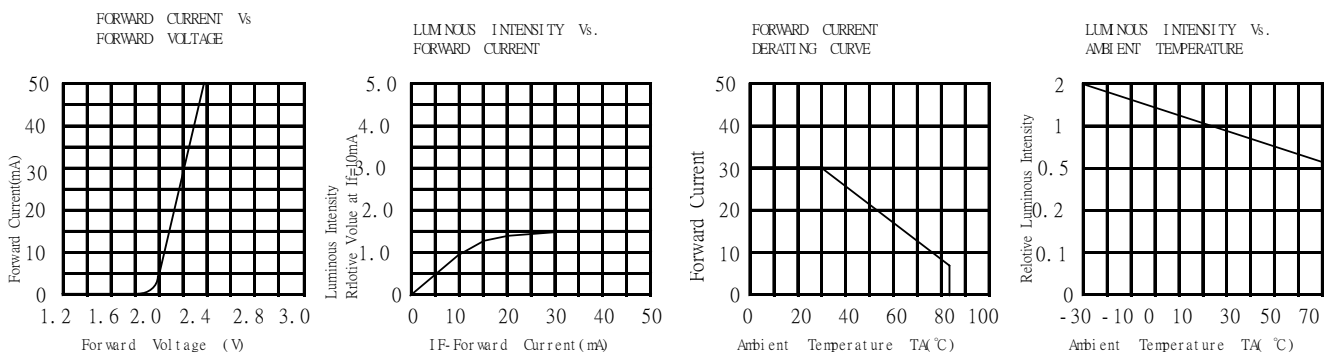

## Part No: B3b-142-TR

### ★ Taped And Reel

#### ■ Taping Dimensions

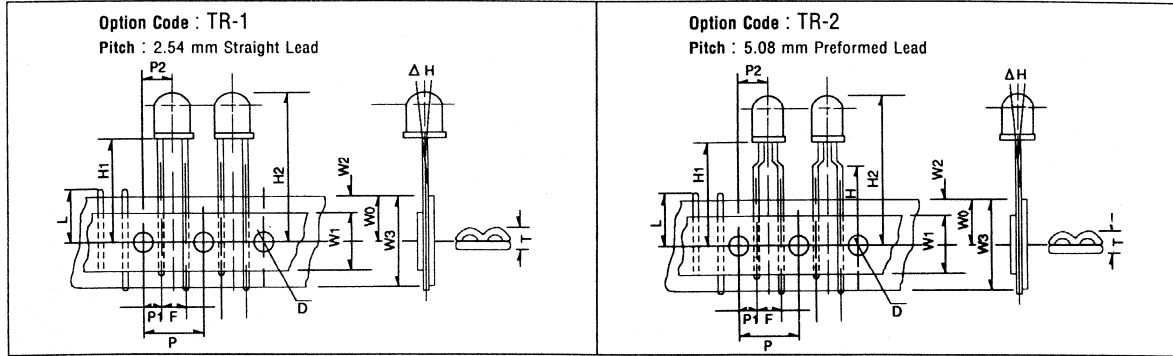

#### ■ Symbol Information for Taping Dimensions

Dimension	Symbol	TR-1		TR-2	
		Minimum mm(inch)	Maximum mm(inch)	Minimum mm(inch)	Maximum mm(inch)
Tape Feed Hole Diameter	D	3.8 (0.149)	4.2 (0.165)	3.8 (0.149)	4.2 (0.165)
Component Lead Pitch	F	2.3 (0.09)	3.0 (0.118)	4.8 (0.188)	5.8 (0.228)
Front-To-Rear Deflection	$\Delta H$	—	2.0 (0.078)	—	2.0 (0.078)
Height of Seating Plane	H	—	—	15.5 (0.61)	16.5 (0.649)
Feed Hole to Button of Component	H1	18.0 (0.708)	19.0 (0.748)	22.4 (0.882)	24.4 (0.961)
Feed Hole to Overall Component Height	H2	—	32.0 (1.259)	—	33.0 (1.299)
Lead Length after Component Height	L	W0	11.0 (0.433)	W0	11.0 (0.433)
Feed Hole Pitch	P	12.4 (0.488)	13.0 (0.511)	12.4 (0.488)	13.0 (0.511)
Lead Location	P1	4.4 (0.173)	5.8 (0.228)	3.15 (0.124)	4.56 (0.179)
Center of Component Location	P2	5.05 (0.198)	7.65 (0.301)	5.05 (0.198)	7.65 (0.301)
Overall Taped Package Thickness	T	—	1.42 (0.055)	—	1.42 (0.055)
Feed Hole Location	W0	8.5 (0.334)	9.75 (0.383)	8.5 (0.334)	9.75 (0.383)
Adhesive Tape Width	W1	14.5 (0.51)	15.5 (0.61)	14.5 (0.51)	15.5 (0.61)
Adhesive Tape Position	W2	0	4.0 (0.157)	0	4.0 (0.157)
Tape Width	W3	17.5 (0.688)	19.0 (0.748)	17.5 (0.688)	19.0 (0.748)

#### ■ Order Information

- (1) Qty Per Reel/Box : 2,000 Pcs
- (2) Order Increments : 2,000 Pcs

#### ■ Remark

• The dimensions of H, H1 and H2 may be different among various models.

#### ■ Package Dimensions

##### ● Reel

Description	Symbol	Specifications	
		Minimum mm(inch)	Maximum mm(inch)
Reel Diameter	D	78.2 (3.07)	380.0 (14.96)
Core Diameter	D1	34.9 (1.37)	102.0 (4.01)
Hub Recess Inside Diameter	D2	28.6 (1.12)	88.0 (3.47)
Arbor Hole Diameter	D3	13.8 (0.54)	38.1 (1.5)
Overall Reel Thickness	T	—	54.0 (2.12)
Inside Reel Flange Thickness	T1	40.0 (1.57)	44.0 (1.73)

##### ● Ammunition Box

Description	Symbol	Specifications	
		Minimum mm(inch)	Maximum mm(inch)
Overall Length	L	334.0 (13.15)	336.0 (13.23)
Overall Width	W	274.0 (10.79)	276.0 (10.87)
Overall Thickness	H	51.0 (2.01)	53.0 (2.09)

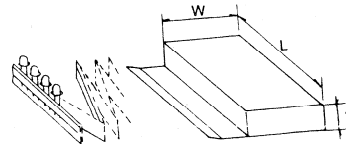
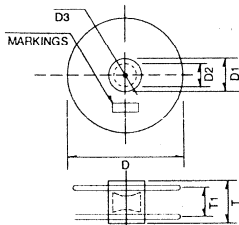



# Light Emitting Diode Lamp



**Part No:B3b-142-TR**

## ★ Reliability Test

No	Item	Test Condition	Test Hours/Cycles	Samples Tested	Acc./Rej
1	Room Temperature DC Oper-ating Life	Ta=25°C, IF=20mA	1000 Hrs	76	0/1
2	Thermal Shock	-10°C (5min)→ (10sec)→+100°C (5min)	100 Cycles	76	0/1
3	Temperature Cycle	-40°C (30min) →(5min)→+85 °C (30min)	100 Cycles	76	0/1
4	High Temp./ High Humi. Test	85°C/85%RH	1000 Hrs	76	0/1
5	High Temperature Storage	Ta=100°C	1000 Hrs	76	0/1
6	Low Temperature Storage	Ta= - 40°C	1000 Hrs	76	0/1
7	Soldering Heat	260°C±5°C	5 Seconds	76	0/1